

DAC-60

Supported Sampling Frequencies
[DSD] 11.2 MHz / 1-bit
[PCM] 384 kHz / 32-bit

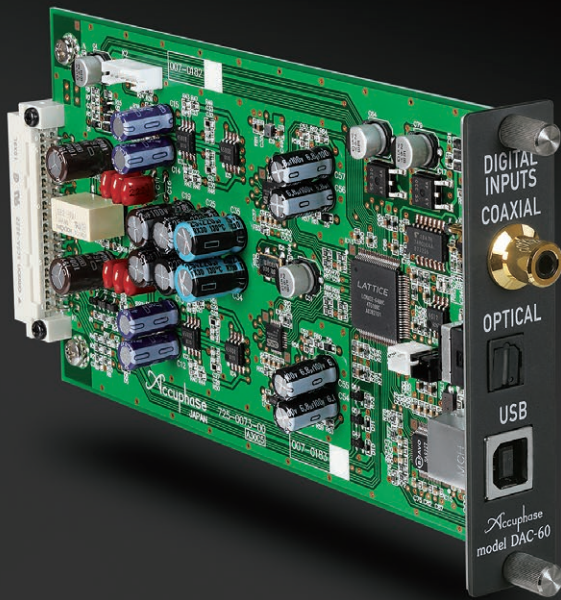

Digital Input Board With USB, Optical, and Coaxial Inputs

Convert signals from various digital source components into high-quality analog signals

The DAC-60 is a digital input board that can input digital signals directly into amplifier units when installed in Accuphase preamplifiers and integrated amplifiers (listed below). Three input types are provided (USB, OPTICAL, COAXIAL) for connection to a broad range of digital devices. The D/A converter adopts the "2MDS+ (Multiple Delta Sigma) converter principle" with ES9016K2M (ESS Technologies) mounted in parallel to convert analog signals that remain extremely true to the original source sound. Born from cutting-edge audio technologies, the DAC-60 is an option board that provides truly high-quality and fully expressive performances.



DAC: ES9016K2M

Supported amplifier units can display the sampling frequency.

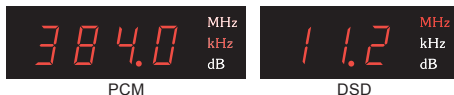

PCM

DSD

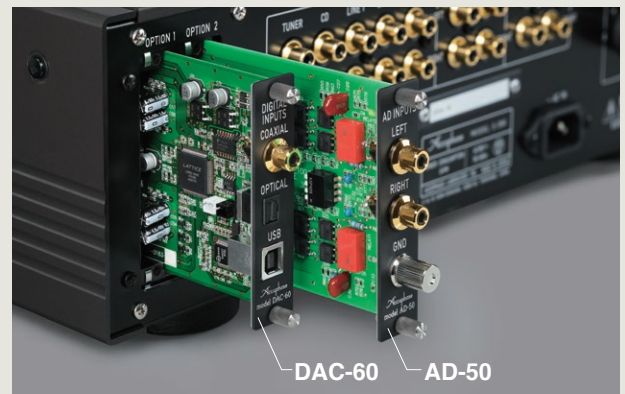
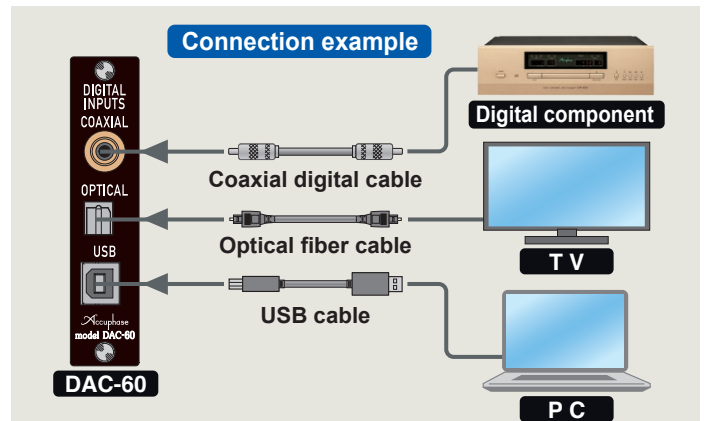

DAC-60 AD-50

DAC input selection method

- When the front panel has a DAC input selector button or switch

Change the input using the button or switch on the front panel.



- When the front panel does not have a DAC input selector button or switch

If power is turned off or a cable disconnected in a model that will not play back, the DAC-60 will automatically select the input signal.

DAC-60 Specifications

- "2MDS+" type D/A converter

USB

Format	USB 2.0 Hi-Speed (480 Mbps) compliant	
Sampling frequencies	DSD	2.8 MHz, 5.6 MHz, 11.2 MHz / 1-bit (11.2 MHz is for ASIO only)
	PCM	32 kHz – 384 kHz / 32-bit
Suitable cable	USB 2.0 cable with Type B connector (max. 2 m)	

OPTICAL

Format	JEITA CP-1212 compliant	
Sampling frequencies	PCM	32 kHz – 96 kHz / 24-bit
Suitable cable	JEITA standard optical fiber cable	

COAXIAL

Format	IEC 60958 AES-3 compliant	
Sampling frequencies	PCM	32 kHz – 192 kHz / 24-bit
Suitable cable	75-ohm coaxial digital cable	

- Supported models (as of May 2021)

C-2150, C-2120(*3), C-2110(*1), C-2000(*1), C-245(*1,*2), CX-260(*1,*2), E-800, E-650, E-600(*3), E-560(*1), E-550(*1), E-530(*1), E-480, E-470(*3), E-460(*1), E-450(*1), E-408(*1), E-380, E-370(*3), E-360(*1), E-350(*1), E-308(*1,*2), E-307(*1,*2), E-280, E-270(*3), E-260(*1), E-250(*1), E-213(*1)

*1 Models: DAC input selection cannot be performed from the front panel. If power is turned off or a cable disconnected in a model that will not play back, the DAC-60 will automatically select the input signal.

*2 Models: Two DAC-** digital input boards cannot be installed.

*3 Models: Playback will use the following sampling frequencies when the signals are input, but the display will read 192.0 kHz.

[PCM] 352.8kHz, 384kHz [DSD] 2.8MHz, 5.6MHz, 11.2MHz

* The capability for playback of music data via a USB connection depends on the operating system and music playback software of the computer.

* For information on computer settings and connection methods when using USB connections, please refer to the computer documentation.

Supplied accessory • USB Utility 3 CD-ROM

*Specifications and design are subject to change without notice for improvements.

Accuphase

ANALOG DISC INPUT BOARD

AD-50

MC/MM Phono Equalizer Amplifier

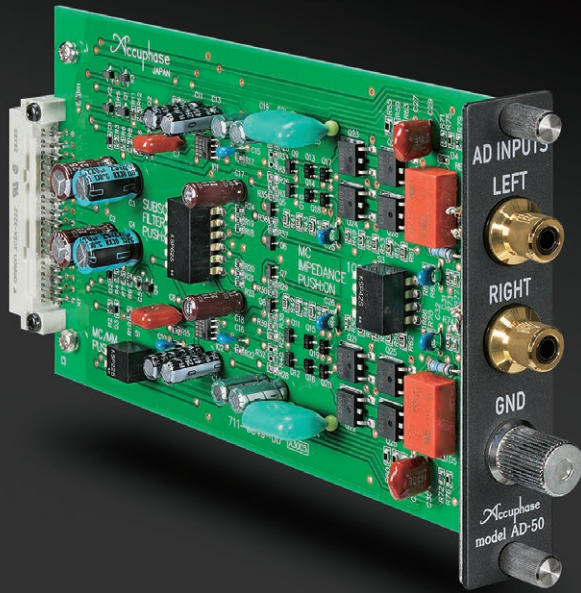

Analog Disc Input Board

High-performance phono equalizer amp for playback of records

The AD-50 is a high-performance phono equalizer amp for truly enjoyable playback of records when installed in any Accuphase preamplifier or integrated amplifier (listed below). It features the latest circuitry topology and carefully selected high-quality materials for low noise and extremely precise RIAA equalization with minimum curve deviation. MC/MM switching can be performed with the controls on the front panel of supported amplifiers. For MC, the impedance most suitable for the cartridge in use can be selected (30/100/300 Ohms). The board also incorporates a subsonic filter to cut woofer flutter caused by record warps. The AD-50 lets true sound enthusiasts enjoy the reemerging world of listening to analog recordings.

MC/MM switching

■ **When the front panel has an MC/MM selector button**

Select using the button on the front panel.

■ **If the front panel does not have an MC/MM selector button**

Select using the switch on the option board.



Performance graphs

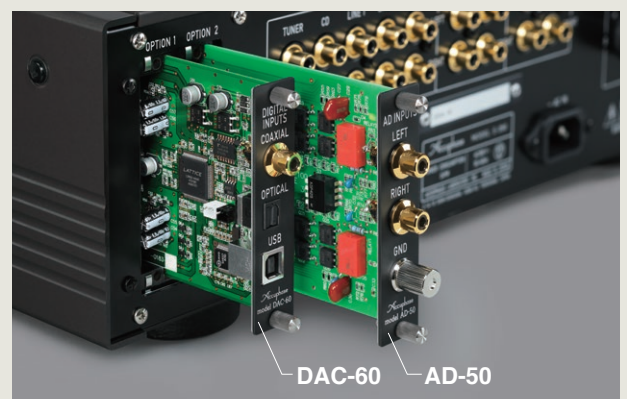
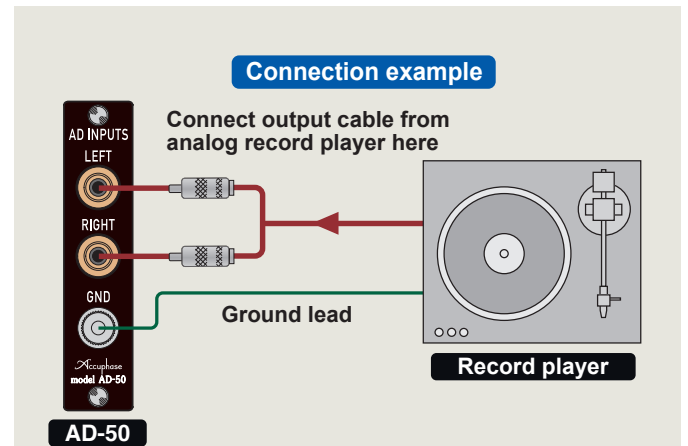
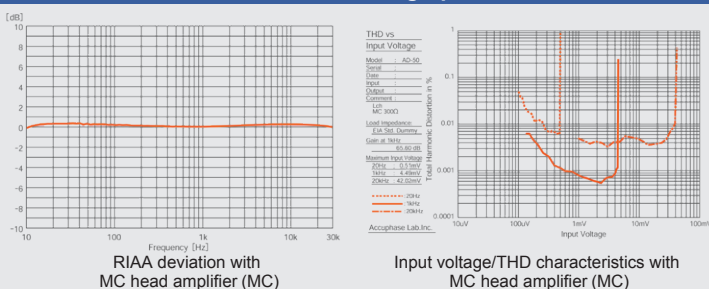

AD-50 Specifications

■ **MC/MM Phono Equalizer Amplifier**

- **MC/MM switching type**
- **Gain**
MC: 66 dB
MM: 40 dB
- **Input impedance**
MC: 30/100/300 Ohms
MM: 47 Kilohms
- **Subsonic filter**
25 Hz -12 dB/octave

■ **Accuphase models that support AD-50 installation**

C-2150, C-2120, C-2110, C-2000(*), C-265(*), C-245(*), CX-260(*), E-800, E-650, E-600, E-560, E-550, E-530(*), E-480, E-470, E-460, E-450, E-408(*), E-407(*), E-406V(*), E-380, E-370, E-360, E-350, E-308(*), E-307(*), E-306V(*), E-280, E-270, E-260, E-250, E-213(*), E-212(*), E-211(*)

*Models: MC/MM selection is not possible from the front panel. Select using the switch on the option board

Accuphase

ACCUPHASE LABORATORY, INC.